

LOWERING TOOLS AND CONTROL CABLE ASSEMBLIES

All gear boxes and lowering tools are of heavy duty design to provide reliability, long life, and ease of operation. They incorporate solid steel heat treated gears for maximum durability and strength. All are equipped with a special automatically actuated disc brake for better load holding ability and the prevention of the load free wheeling. They are essential for lifting operations. Available for permanent installation or portable use indoors or outdoors for wall mounting, tower mounting, or pole mounting. Each system is custom tailored to work with required load and operation of the raising and lowering specifications.

**LT-4-XX
LT-5-XX**
For Security
Locking Box

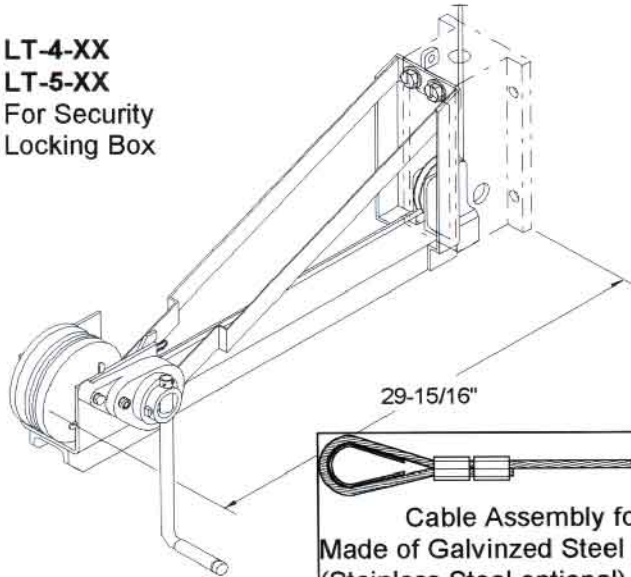

CAT. NO LT-1R
**PORTABLE LOWERING TOOL
FOR ROUND POLES**

CAT. NO LT-1S
**PORTABLE LOWERING TOOL
FOR SQUARE POLES**

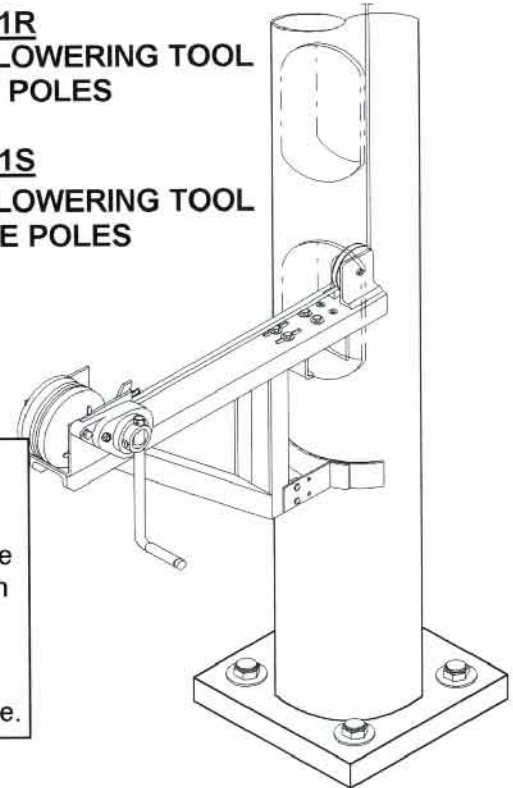

Cable Assembly for LT-4,LT-5, & GB-2P
Made of Galvanized Steel 5/32"-7x19 preformed cable (Stainless Steel optional). Minimum breaking strength of 2400 lbs. Looped and crimped to accept cable connector. Other end has crimped on copper stop. Camera cable assembly is also looped and crimped with connecting link to connect to Lowering Tool cable.

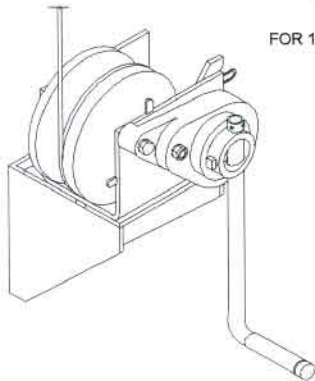

FOR 1/2" MOUNTING BOLTS

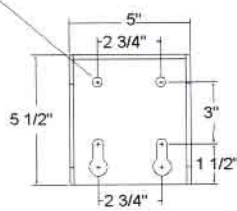

CAT. NO. GB-2P
**PERMANENT OR PORTABLE
WALL MOUNTED GEAR BOX F**

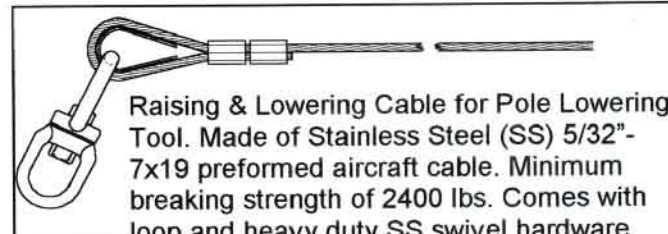

Raising & Lowering Cable for Pole Lowering Tool. Made of Stainless Steel (SS) 5/32"-7x19 preformed aircraft cable. Minimum breaking strength of 2400 lbs. Comes with loop and heavy duty SS swivel hardware cable attachment. Wall mount termination cable assys come with Galvanized Cable and a twisted link cable connector.

Catalog # (with Lowering Tool cable length)	Min Load Lbs.	Drum Capacity	Max Load Lbs.
GB-2P-XX (portable)	18	125 ft.	300
LT-1R-XX (round poles)	16	125 ft.	300
LT-2R-XX (round poles)	18	250 ft.	300
LT-1S-XX (square poles)	16	125 ft.	300
LT-4-XX (wall, tower,	16	125 ft.	300
LT-5-XX (wall, tower,	18	250 ft.	300

CATALOG NO.	OPTIONS DEFINITION
LT-DRI-CL	Drill motor with drill mounted adapter kit and clutch to be used with our Gear Box, for up to 300 lb. loads.

* All Camera Lowering Systems gear boxes and lowering tools are designed for material handling usage only.
* Not for lifting people, or things over people.
* Specifications subject to change without notice.

**DRILL MOTOR ACCESSORY FOR POLE, TOWER, AND
WALL MOUNTED LOWERING TOOL**

HAND HELD DRILL ASSY. COMES WITH AUTOMATIC RESETTING
ADJUSTABLE OVERLOAD CLUTCH

Overload Clutch Specifications:

CLUTCH TYPE: Lubricated ball indent-totally enclosed-
adjustable torque limiting. Coupling/clutch
model to directly connect two shaft ends.
SPRING TYPE: Coil spring. Varied quantities depending
on torque range.
TORQUE RANGE: 60 to 300 lb.-in.
HUB SHAFT SIZE: 3/8" square w/spring loaded pin
(clutch end). 7/16" hex for inserting into 1/2"
capacity drill chuck.
SOCKET SHAFT SIZE: 3/8" square w/spring loaded
retaining pin (clutch end). 1/2" square w/pin for
winch drive fitting.
TORQUE ADJUST: Open-end wrench type adjusting
nut. Snap ring tool included with clutch.
WINCH DRIVE: 1-1/8" hex socket with 1/2" square drive
(clutch).
MAX. OPERATING SPEED: 350 RPM
DIMENSIONS: Clutch: 1-1/2" diameter and 1-5/8" long.
Complete assembly: 8-1/2" overall length.
WEIGHT: 2 lbs.

Drill Motor Specifications:

DRILL TYPE: 1/2" Double insulated, heavy duty,
reversible, variable speed with 'D' -handle.
CHUCK SIZE: 1/2" key type chuck. Key included
with drill.
ELECTRICAL: Nom. 5 amp universal motor; 115
volts AC.
TORQUE: Develops nominal 170 lbs.-in.
SPEED/H.P: .5 H.P. No load speed of 350 R.P.M.
DIMENSIONS: Overall length: 15-1/8"
WEIGHT: Approx. 7 lbs. 6 oz.

*Drill motor manufacturer and specifications subject
to change without notice. Contact the factory for
information on the latest specifications.*

